

Things You Don't Know about IC Design -Semiconductor/Chip, or Systems?

吳卓諭

Institute of Communications Engineering
National Yang Ming Chiao Tung University

2025/11/24

EE-CS is ubiquitous and dominant nowadays



What they have in common?



- Many guys would claim

Since they all have “IC-chips-inside”,
IC/semi-conductors must be prominent!

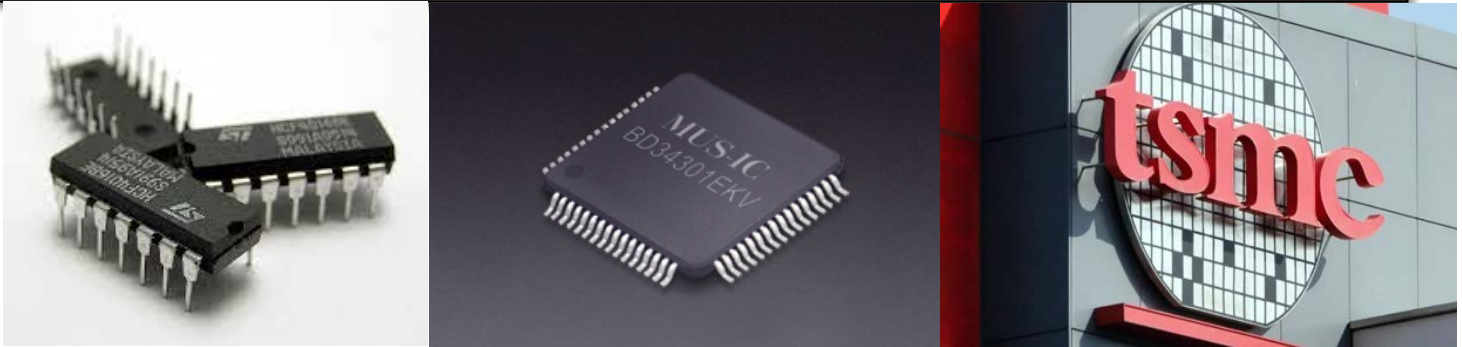

- Doubtlessly just a tip of the iceberg!
 - What's the whole?

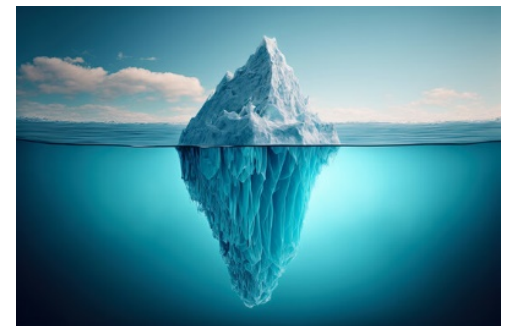

What's all about **IC design**?

Immediately comes to your mind are:
Microelectronics, Circuits, VLSI,
Semi-conductor process...

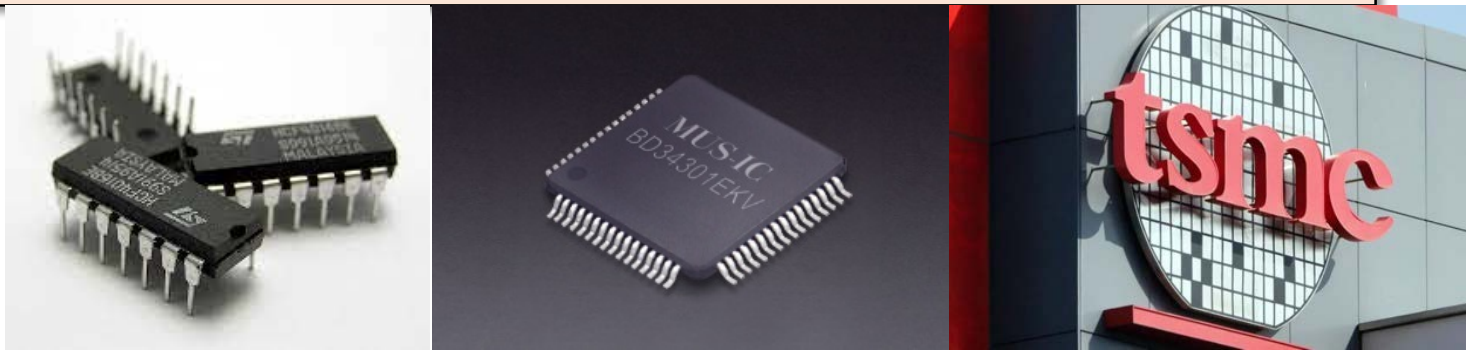

- Yet, these are for **fast production** (nano processes) of IC chips, stressing hardware, a “**strong body**” (good conductivity, heat dissipation)!

What's all about **IC design**?

However, a strong body is overall just a body, **if without a brain, the software!**

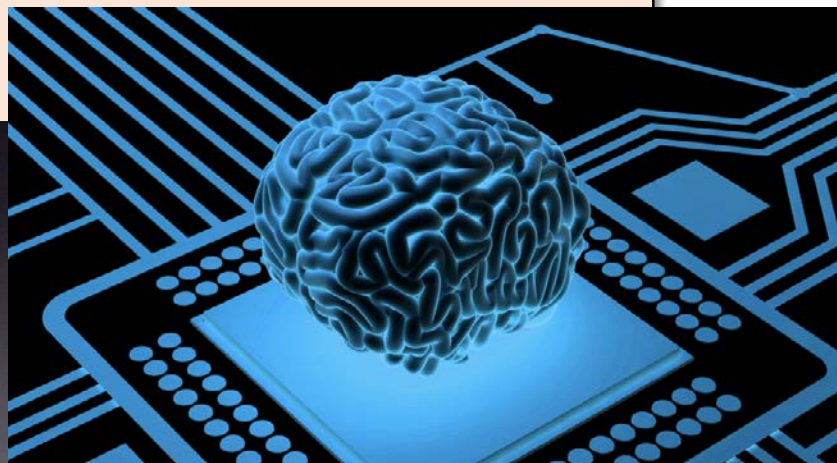

- And a good brain of IC chips is **the key to smartness and intelligence!**

What's all about **IC design**?

What is the **brain** of an IC chip?

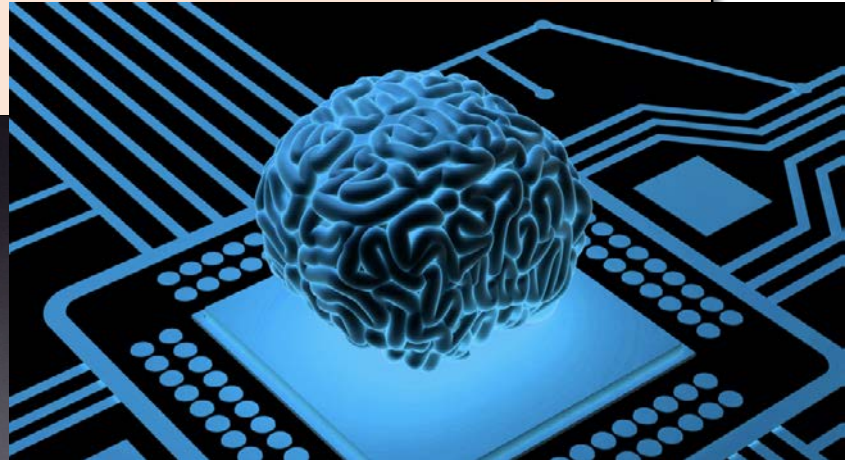
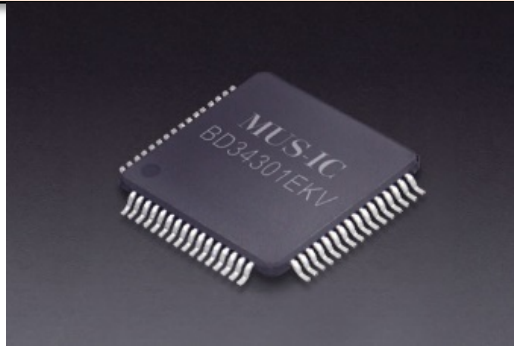

- The answer is **Algorithms!**



What's all about **IC design**?

An algorithm is a finite sequence of **mathematically rigorous** instructions, typically used to solve a class of specific problems or to perform a computation (from Wikipedia).

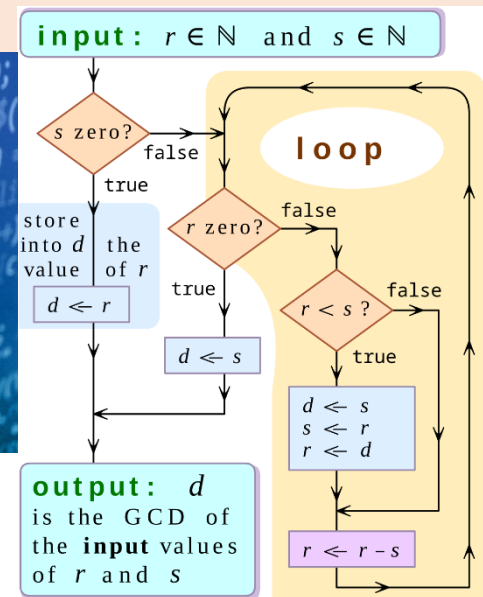
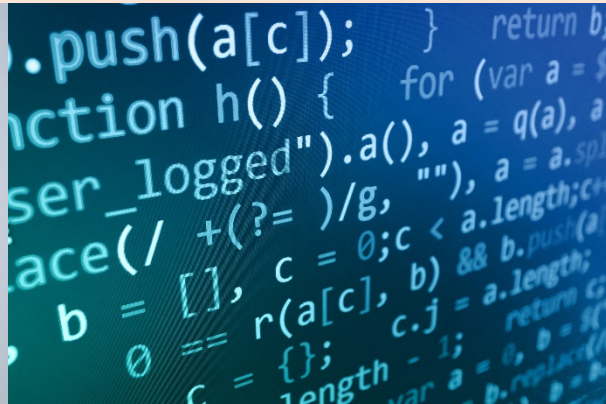

What's all about **IC design**?

Why “mathematically rigorous”?!

A chip's brain must **respond fast, work reliably, and make almost no error...all the way become intelligent!**



- With a good brain/algorithm inside, IC chips can perform **fast and high-accuracy computations...intelligent processing!**

What's all about **IC design**?

- Where did mathematics come from?
- By “chip” only, you miss the cores

AI chips, **communication** chips, **control** chips, **sensor** chips, **bio-medical** chips,...many more, all “**system** + chip”

- Need mathematics to formalize system behavior
 - Mathematical system model
 - First step to design algorithm, the brain of chips

What's all about **IC design**?

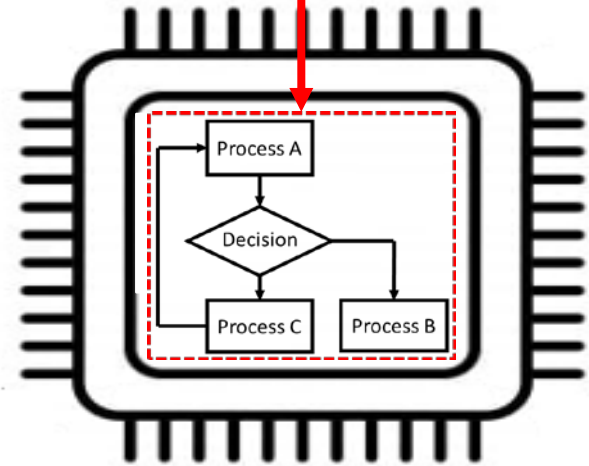
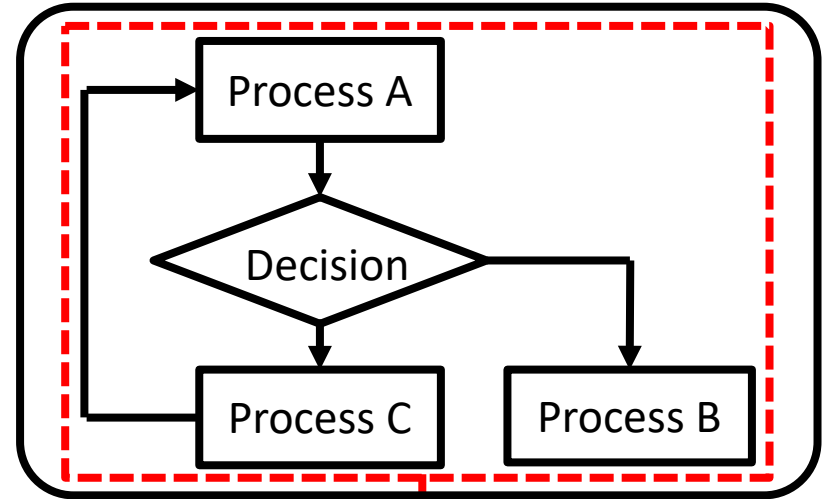
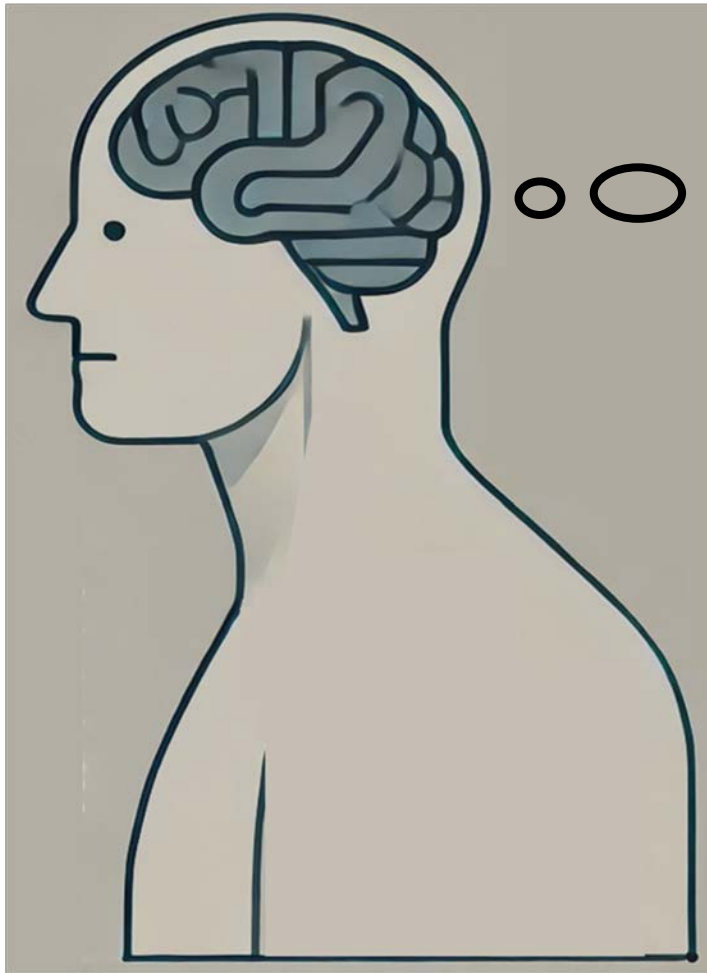

- So, you have two options for IC-career

Semiconductor and **IC production, foundry!**

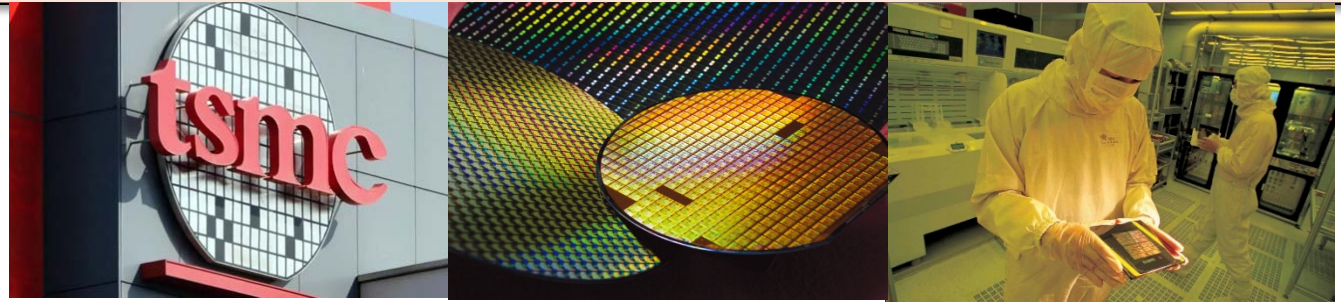

Or...

IC/Algorithm Design: Invent/design new algorithms and systems, integrating tones of chips cleverly!



Large in LEMS extends beyond CEOs, internet companies, and private enterprises, countries and small-to-medium businesses, further bolstering this positive revenue

3Q23 Revenue Ranking for Top Ten IC Design Houses

(Unit: Million USD)

Rank	Company	Revenue			Market Share	
		3Q23	2Q23	QoQ	3Q23	2Q23
1	NVIDIA	16,512	11,332	45.7%	36.9%	29.8%
2	Qualcomm	7,374	7,174	2.8%	16.5%	18.9%
3	Broadcom	7,198	6,897	4.4%	16.1%	18.2%
4	AMD	5,800	5,359	8.2%	13.0%	14.1%
5	MediaTek	3,474	3,195	8.7%	7.8%	8.4%
6	Marvell	1,393	1,335	4.4%	3.1%	3.5%
7	Novatek	913	987	-7.5%	2.0%	2.6%
8	Realtek	842	856	-1.7%	1.9%	2.3%
9	Will Semiconductor	752	528	42.3%	1.7%	1.4%
10	Cirrus Logic	481	317	51.7%	1.1%	0.8%
Combined Total		44,737	37,980	17.8%	100%	100%

Notes:

1. This ranking only includes the top ten companies that publicly disclosed their financial reports.
2. The ranking considers Qualcomm's revenues solely from its QCT division, excludes OEM/IP revenues for NVIDIA, includes only semiconductor division revenues for Broadcom, and counts only semiconductor design and sales revenues for Will Semiconductor.

3. NTD:USD exchange rate= 3Q23 31.6957 ;2Q23 30.7124

4. RMB: USD exchange rate=3Q23 7.2445; 2Q23 7.0130

Source: TrendForce, Dec., 2023

Again, what they have in common?



Algorithms inside tones of chips!



Once again, a high-level look into them...



Data gathering, transfer, and processing!



That's all what 電信所 is all about!!



AI世代來臨—資料洪流驅動6G通訊革命

NVIDIA 與 Nokia 攜手打造 AI 原生無線網路 (AI-RAN)

開啟邁向 AI-native 6G 時代 的關鍵轉折

➤ NVIDIA 投資 10 億美元於 Nokia，推動 AI-RAN 創新

➤ 市場規模預估 2030 年將超過 **2,000 億美元**

➤ T-Mobile U.S. 將參與 2026 年 AI-RAN 實地測試

➤ NVIDIA 將推出可支援6G的通訊運算平台—NVIDIA
Arc Aerial RAN Computer



Powering the AI-native 6G Era
AI 驅動，重新定義通訊未來

Powerful algorithms and novel systems for connecting the world, and beyond...!



“Sometimes it is the people no one can imagine anything of who do the things no one can imagine.”

— Alan Turing

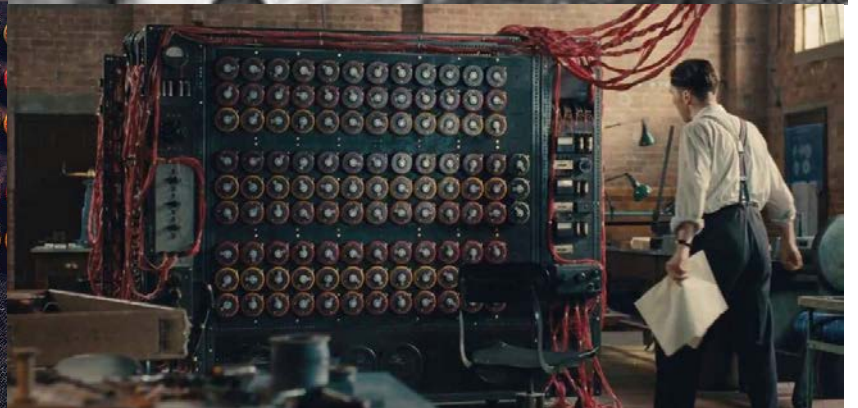
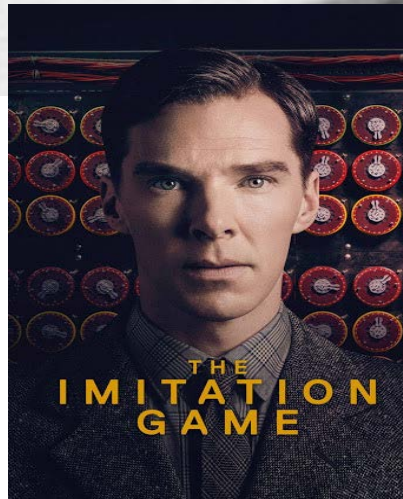
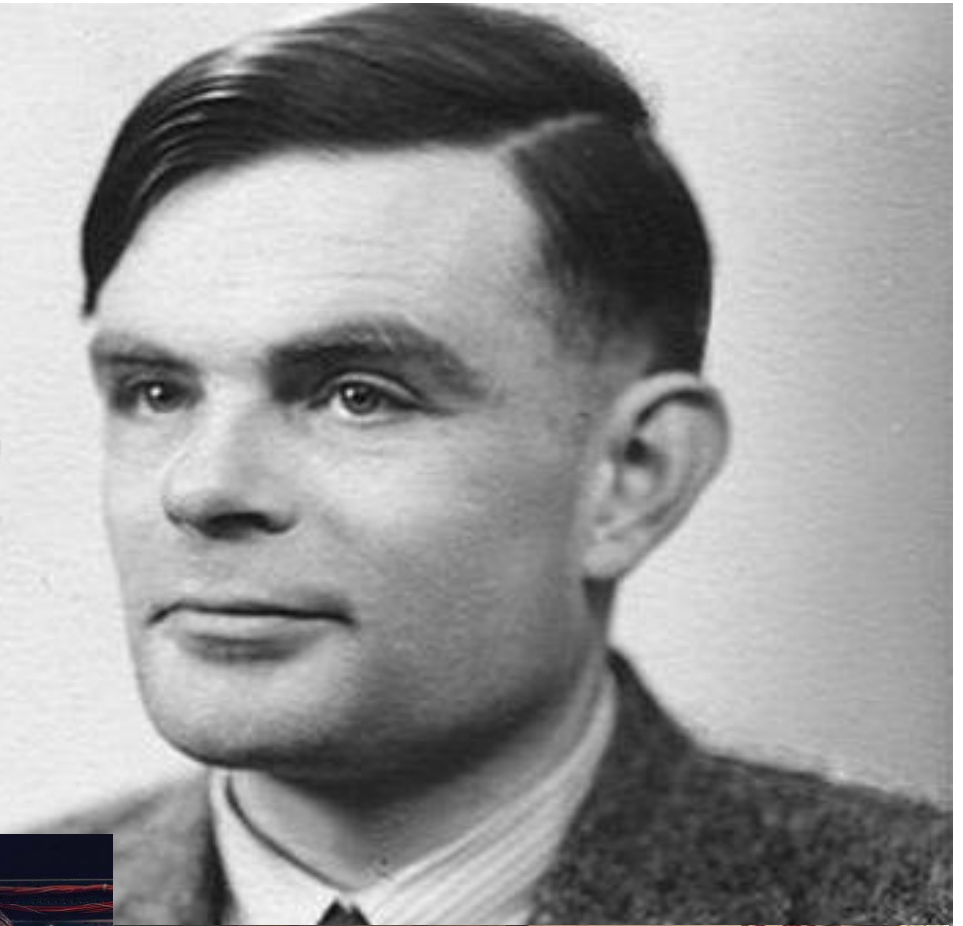

Appendix

6G方興未艾

SETTING SIGHTS ON GENERATIONAL LEAP

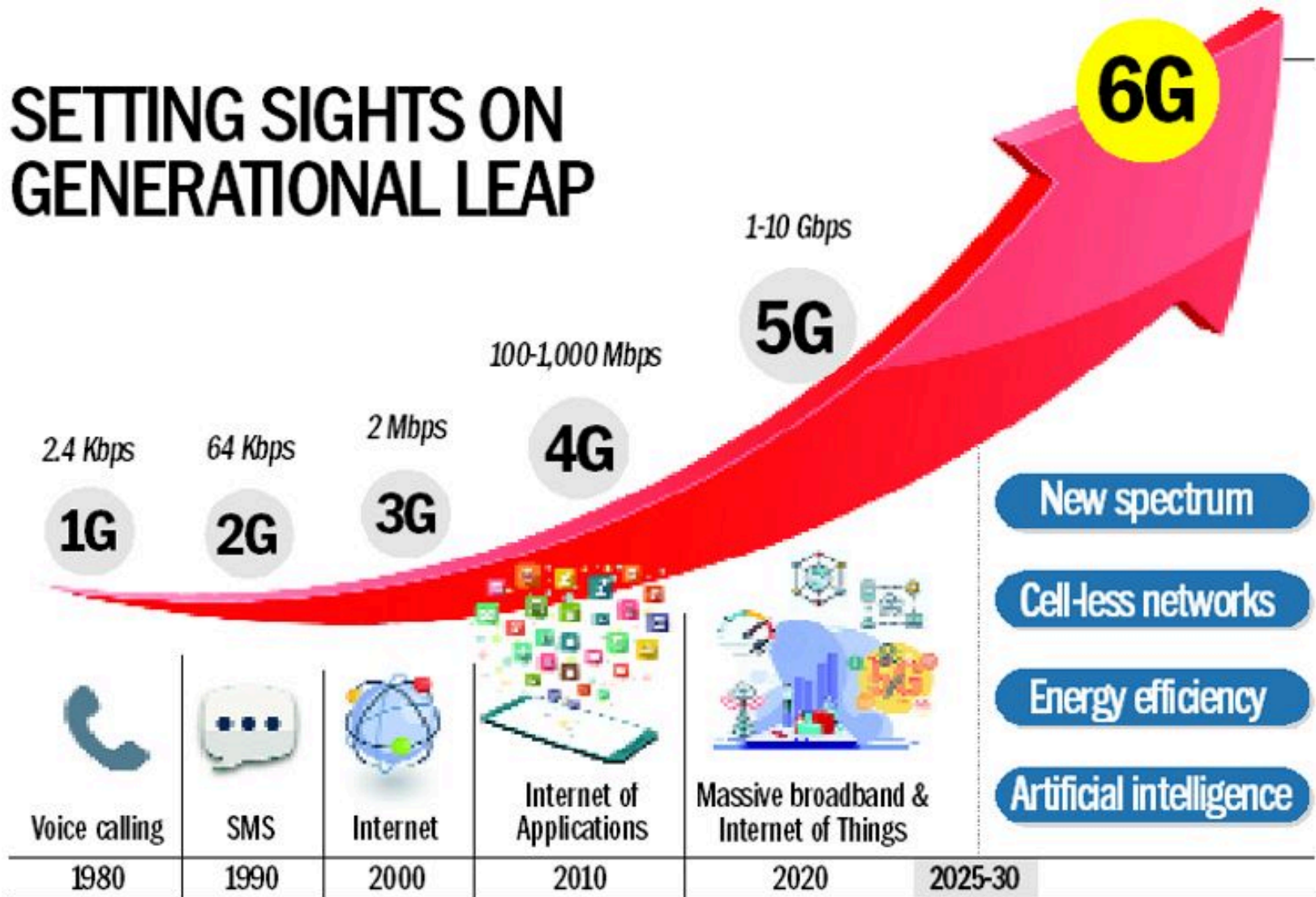

電信產業簡介

✓ 5G 企業用戶的市場規模

- 23億→317億美金(CAGR 54%)
- 主要集中在接取端

✓ 配合雲端開放電信網趨勢:

- 雲端軟硬整合通訊運算平台
- 通訊、邊緣運算、人工智慧
- mmWave & THz 射頻晶片
- 智慧雷達、天線技術

✓ AIoT健康照護

- 智慧醫療、數位醫學中心
- 2025→5,343億美金(CAGR 19.9)

5G ENTERPRISE MARKET, BY REGION (USD BILLION)

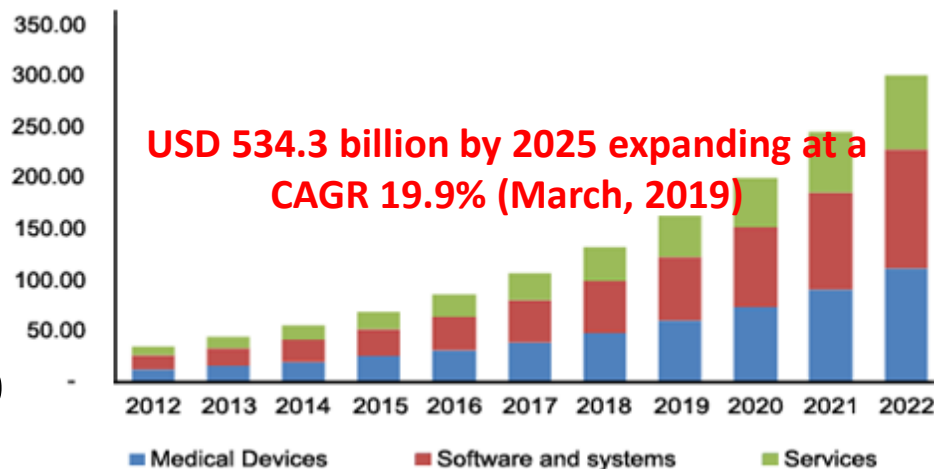
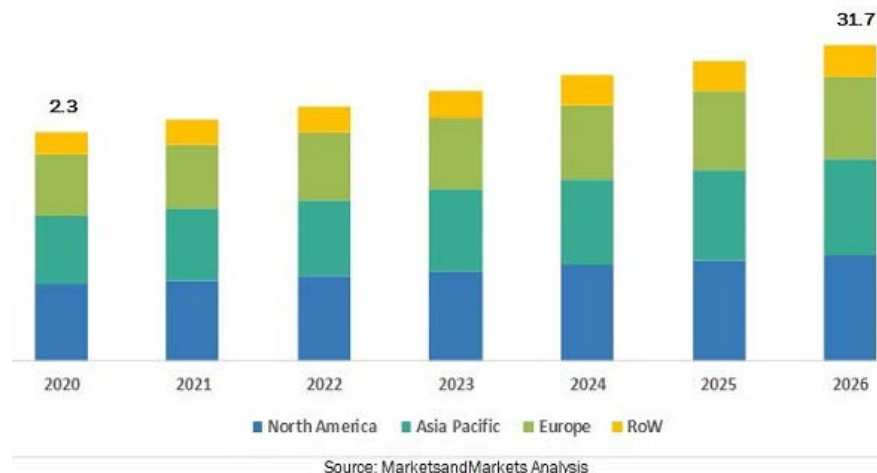

台灣電信產業聚落

✓ 台灣電信產業之焦點

➤ B5G /6G 智慧無線通訊網路

- 智慧物聯網: 智慧製造、健康照護、智慧運輸

➤ 無線通訊接取端與設備

✓ 台灣之電信走廊 (Telecom Corridor)

➤ 通訊晶片: 聯發科、瑞昱、絡達

➤ 網路通訊系統: 啟碁、合勤、智邦、正文、明泰、智易

➤ 行動通訊裝置: 鴻海、華碩、宏碁、廣達、仁寶、宏達電

➤ 工業物連網: 研華、微軟、亞馬遜

➤ 外商: Qualcomm、Apple、Intel、Broadcom、Google、Amazon